



OPERATOR'S AND PARTS MANUAL

MODEL D450 EARTH AUGER ATTACHMENT



PALADIN
LIGHT CONSTRUCTION GROUP

 **BRADCO**

 **FFC**

 **HARLEY**

 **McMILLEN**

 **SWEEPSTER**

The Power of Combined Excellence



SERIAL NUMBER: _____

MODEL NUMBER: _____

Manual Number: 22668

Part Number: 22668

Rev. 11/05

TO THE OWNER

GENERAL COMMENTS

Congratulations on the purchase of your new McMillen Earth Auger Attachment. Your earth auger was carefully designed and manufactured to give you many years of dependable service. Your earth auger will require some minor maintenance (such as cleaning and lubricating) to keep it in top working condition. Be sure to observe all maintenance procedures and safety precautions in this manual, on the safety decals located on the attachment, and on any equipment on which the earth auger is mounted.

ABOUT THIS MANUAL

This manual has been designed to help you to do a better, safer job. Read this manual carefully, and become familiar with the operating procedures before attempting to operate your earth auger. Remember, never let anyone operate this earth auger without them having read and completely understand the "Safety Precaution" and "Operating Instructions" sections of this manual, or having them be fully trained by an experienced, qualified person who has read and completely understands the "Safety Precautions" and Operating Instructions".

After reading this manual, if you have any questions about your attachment please contact us immediately as follows:

NORTH AMERICAN TOLL FREE: (800) 922-2981
Outside North America: (563) 922-2981
Fax: (563) 922-2700

SERVICE

When servicing this product, remember to use only manufacturer replacement parts. Substitute parts may not meet the standards required for safe, dependable operation.

To facilitate parts ordering, record the model and serial number of your unit in the space provided on this page. This information may be obtained from the identification plate located on the product.

MODEL: _____ **SERIAL NO.** _____

Your parts department needs this information to insure that you receive the correct parts or attachments for your specific earth auger.

McMILLEN®

P.O. Box 266 • Delhi, Iowa 52223 • Phone (563) 922-2981 • Fax (563) 922-2700
North American Toll Free (800) 922-2981

M-102
4-18-05-4

TABLE OF CONTENTS

Letter To The Owner	1
Safety Information	4-5
Skid Steer Loader & Other Quick Attach Mountings - Exploded View, Parts List & Installation Instructions	7
Backhoe & Excavator Mountings- Exploded View, Parts List & Installation Instructions	8
Universal Loader Mounting #21235- Exploded View, Parts List & Installation Instructions	9
3-Point Hitch Mountings #21272 - Exploded View	10
3-Point Hitch Mountings #21272- Parts List & Installation Instructions	11
Down Pressure Kit #21273 - Exploded View & Parts List	12
Down Pressure Kit #21273 - Installation & Operating Instructions	13
Hydraulic System Hook-up & Operating Instructions	14
Maintenance Instructions	15
Model 450 Hydraulic Drive Unit - Specifications, Exploded View & Parts List	16
Troubleshooting	17
Auger Parts List	18



SAFETY INFORMATION

TO THE OPERATOR

Your personal safety is a concern of ours. It should also be of concern to you. It is the responsibility of all operators to read and understand this entire manual before installing, operating or servicing this equipment. Pay particular attention to cautions, warnings and safe operating procedures. Be a safe and qualified operator. Operate your equipment with care and good judgement and see to it that it is properly maintained.

SAFETY ALERT SYMBOL



This Safety Alert Symbol Means:
ATTENTION! BECOME ALERT!
YOUR SAFETY IS INVOLVED!

When you see it pay attention and follow the instructions in the safety message.

The safety alert symbol is generally used in conjunction with a key signal word to emphasize special information. The signal words listed below carry a specific meaning and should be carefully read and understood:

- DANGER:** Indicates an imminently hazardous situation which, if not avoided, will result in death or serious injury.
- WARNING:** Indicates a potentially hazardous situation which, if not avoided, could result in death or serious injury.
- CAUTION:** Indicates a potentially hazardous situation which, if not avoided, may result in minor or moderate injury. It may also be used to alert against unsafe practices.

REPLACEMENT SAFETY DECALS

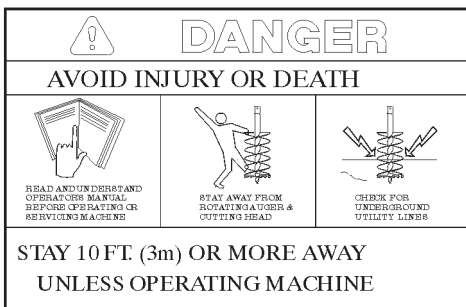











WORN, DAMAGED OR ILLEGIBLE SAFETY DECALS MUST BE REPLACED.

New safety decals can be ordered from McMillen. Two (2) #22680 (89-P2-237A) Safety Decals must be displayed on each McMillen Hydraulic Earth Auger Drive Unit. Decals should be located on opposite sides of the drive unit from each other.



SAFETY INFORMATION

THE USE OF THIS EQUIPMENT IS SUBJECT TO CERTAIN HAZARDS WHICH CANNOT BE PROTECTED AGAINST MECHANICAL MEANS OR PRODUCT DESIGN. ALL OPERATORS OF THIS EQUIPMENT MUST READ AND UNDERSTAND THIS ENTIRE MANUAL, PAYING PARTICULAR ATTENTION TO SAFETY AND OPERATING INSTRUCTIONS, PRIOR TO USING THE MCMILLEN HYDRAULIC EARTH AUGER. IF THERE IS SOMETHING IN THIS MANUAL YOU DO NOT UNDERSTAND, ASK YOUR SUPERVISOR TO EXPLAIN IT TO YOU. FAILURE TO OBSERVE THESE SAFETY PRECAUTIONS CAN RESULT IN DEATH OR SERIOUS INJURY OR SERIOUS EQUIPMENT DAMAGE.

-  All bystanders should be kept a minimum of 10 feet (3 meters) away from working area of the earth auger.
-  Always wear an OSHA approved hard hat and safety eye protection when operating or servicing this equipment. Do not wear loose fitting clothing, flopping cuffs, dangling neckties and scarves, or rings and wrist watches that can catch moving parts.
-  An operator must not use drugs or alcohol which can change his alertness or coordination. An operator taking prescription or over-the-counter drugs should seek medical advise on whether or not he can safely operate equipment.
-  Always locate underground electrical wires, telephone cables, gas, water and sewer lines before digging. Maintain safe clearance and avoid contact with any underground or overhead utility lines or electrically charged conductors.
-  Never alter or remove any safety decals or shields. Replace all missing or damaged safety decals or safety shields. Check this manual for location of these items and replace immediately if damaged or illegible.
-  Never adjust a relief valve for pressure higher than recommended by vehicle manufacturer.
-  Whenever changing or installing this or other attachments, make sure all connections are securely fastened.
-  Travel only with the earth auger in a safe transport position to prevent uncontrolled movement. Drive slowly over rough ground and on slopes. Tether earth auger with a chain, if necessary, to prevent uncontrolled swinging of earth auger when moving from hole to hole. Remove earth auger from vehicle when transporting to and from job site.
-  Before exiting vehicle, lower earth auger to ground, turn off vehicle engine and lock vehicle brakes.
-  Never check a pressurized system for leaks with your bare hand. Oil escaping from pinhole leaks under pressure can penetrate skin and could cause serious infection. Hold a piece of cardboard up next to suspected leaks and wear a face shield or safety eye protection. If any fluid is injected into the skin, it must be removed immediately by a doctor familiar with this type of injury.
-  Before disconnecting hydraulic lines or fittings be sure to relieve all pressure by cycling all hydraulic controls after shutdown. Remember hydraulic systems are under pressure whenever the engine is running and may hold pressure after shutdown. Before applying pressure to the system make sure all connection are tight and that there is no damage to lines, fittings and hoses.
-  Flow and pressure gauges, fittings and hoses must have a continuous operating pressure rating of at least 25% higher than highest pressures of the system.
-  Avoid steep hillside operation which could cause the vehicle to overturn. Consult your vehicle operator's and safety manuals for maximum incline allowable.
-  Never perform any work on an earth auger unless you are authorized and qualified to do so. Always read the operator service manual(s) before any repair is made. After completing maintenance or repair, check for correct functioning of the earth auger. If not functioning properly always tag "DO NOT OPERATE" until all problems are corrected.
-  This manual covers the safe use, installation, operation and service instructions for the earth auger only. Always read the operating and safety manuals prepared for your vehicle and any other attachments before using them.

SKID STEER LOADER & OTHER QUICK ATTACH MOUNTINGS

EXPLODED VIEW, PARTS LIST & INSTALLATION INSTRUCTIONS

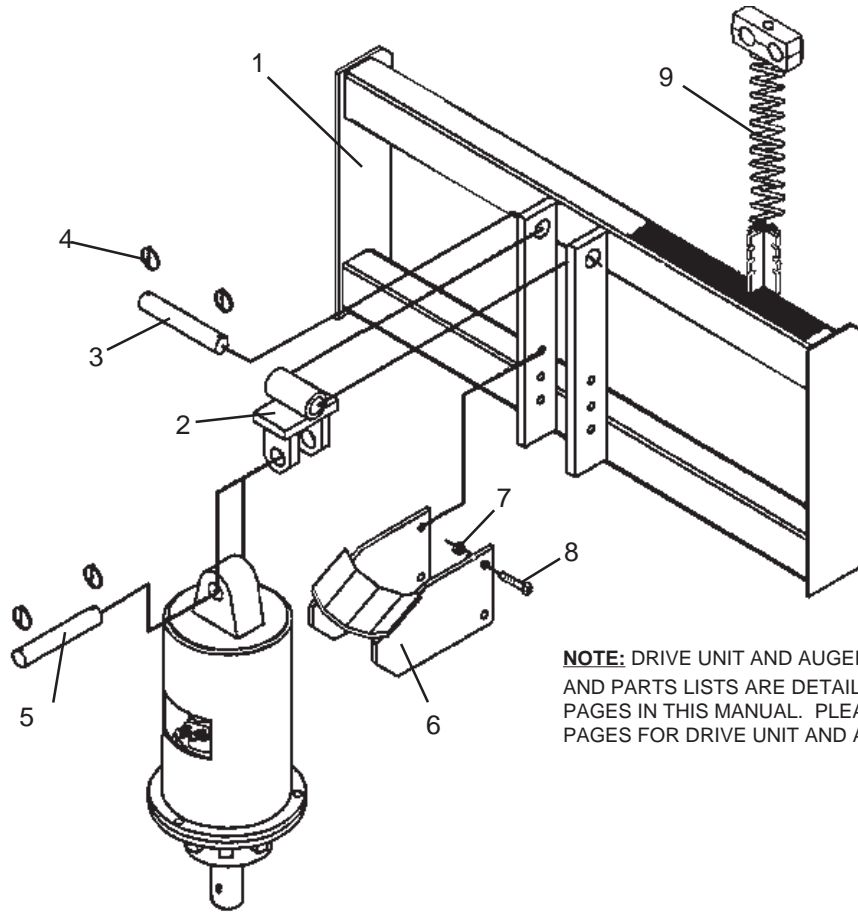

NOTE: DRIVE UNIT AND AUGER EXPLODED VIEWS AND PARTS LISTS ARE DETAILED ON SEPARATE PAGES IN THIS MANUAL. PLEASE REFER TO THOSE PAGES FOR DRIVE UNIT AND AUGER PARTS BREAKDOWN.

REF. #	PART #	DESCRIPTION	QTY REQ
1	VARIABLES	Quick Attach Mounting Bracket	1
2	21694	Swivel Weldment	1
3	22255	Pin, 1.25" Dia. x 7.25" Long	1
4	21169	Lynch Pins	4
5	22256	Pin, (included with drive unit)	1
6	21668	Mounting Cradle	1
7	1228	.50" - 13 Hex Nut	4
8	1092	.50" - 13 x 2" Gr.5 Bolt	4
9	21690	Spring Assembly (.50" Hose)	1
9	21693	Spring Assembly (.75" Hose)	1

1. READ AND UNDERSTAND ALL SAFETY INFORMATION BEFORE ATTEMPTING INSTALLATION.
2. Remove bucket or other attachment from vehicle quick attach mechanism.
3. Attach quick attach mounting bracket (1) to vehicle quick attach mechanism as per vehicle manufacturer's recommendations.
4. Attach swivel weldment (2) to the quick attach mounting bracket (1) with pin (3). secure pin (3) with lynch pins (4).
5. Attach and secure drive unit to swivel weldment (2) with pin(5) and lynch pins(4) provided with the drive unit assembly.
6. Attach and secure auger to drive unit with bolt and nut provided with drive unit assembly.
7. Refer to the "HYDRAULIC SYSTEM HOOK-UP" section in this manual for hydraulic connection instructions and recommendations.

BACKHOE & EXCAVATOR MOUNTINGS

EXPLODED VIEW, PARTS LIST & INSTALLATION INSTRUCTIONS

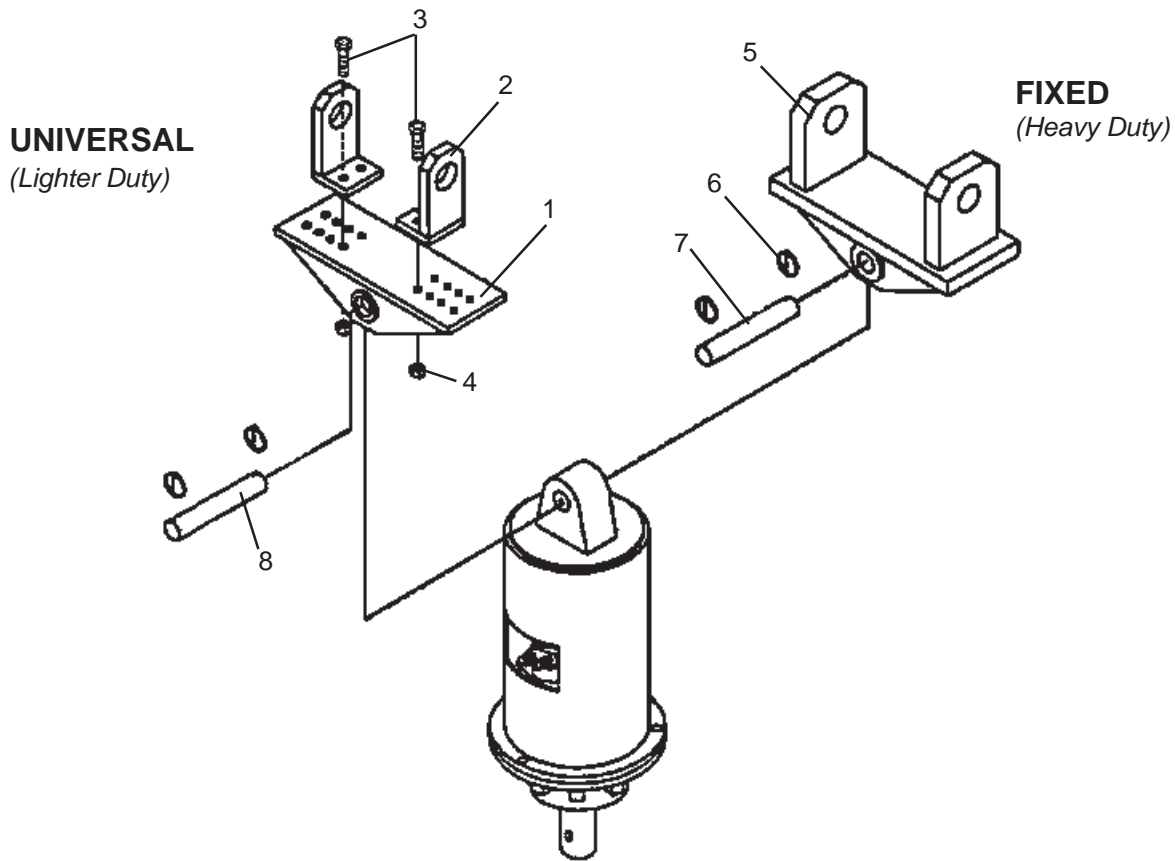

NOTE: DRIVE UNIT AND AUGER EXPLODED VIEWS AND PARTS LISTS ARE DETAILED ON SEPARATE PAGES IN THIS MANUAL. PLEASE REFER TO THOSE PAGES FOR DRIVE UNIT AND AUGER PARTS BREAKDOWN.

REF.#	PART#	DESCRIPTION	QTY REQ'D
1	21626	Backhoe Base Weldment	1
2	Varies	Backhoe Adaptor Ear	2
3	1091	.50"-13 x 1.75" Bolt Gr. 5	4
4	1841	.50" - 13 Locknut	4
5	Varies	Fixed Backhoe Mount	1
6	21169	Lynch Pins	2
7	22255	1.25" Pin x 7.25" Long	1
8	22256	Pin (included with drive unit)	1

1. READ AND UNDERSTAND ALL SAFETY INFORMATION PRIOR TO ATTEMPTING INSTALLATION.
2. Remove bucket from dipper arm and curl cylinder pin connections. The dipper arm pin will be used to attach backhoe mounting to backhoe dipper arm. Curl cylinder pin will not be required for earth drill installation.
3. If using a Universal (adjustable width) Backhoe Mounting, assemble by spacing the two ears (2) to the same width as the dipper arm and secure to the backhoe swivel base (1) with four bolts (3). Secure bolts (3) and nuts (4). **After determining correct width, backhoe ears (2) must be welded to backhoe swivel base (1).**
4. Attach backhoe mounting (universal or fixed) to the dipper arm using the dipper arm pin removed from bucket in step 1. Secure bucket pin as per vehicle manufacturer's recommendation.
5. Attach and secure drive unit to backhoe mounting with pin (6) and Lynch Pins (8) provided with the drive unit assembly.
6. Attach and secure auger to drive unit using bolt and nut provided with drive unit assembly.
7. Refer to the 'HYDRAULIC SYSTEM HOOK-UP' section in this manual for hydraulic connections instructions and recommendations.

#21235 UNIVERSAL LOADER MOUNTINGS

EXPLODED VIEW, PARTS LIST & INSTALLATION INSTRUCTIONS

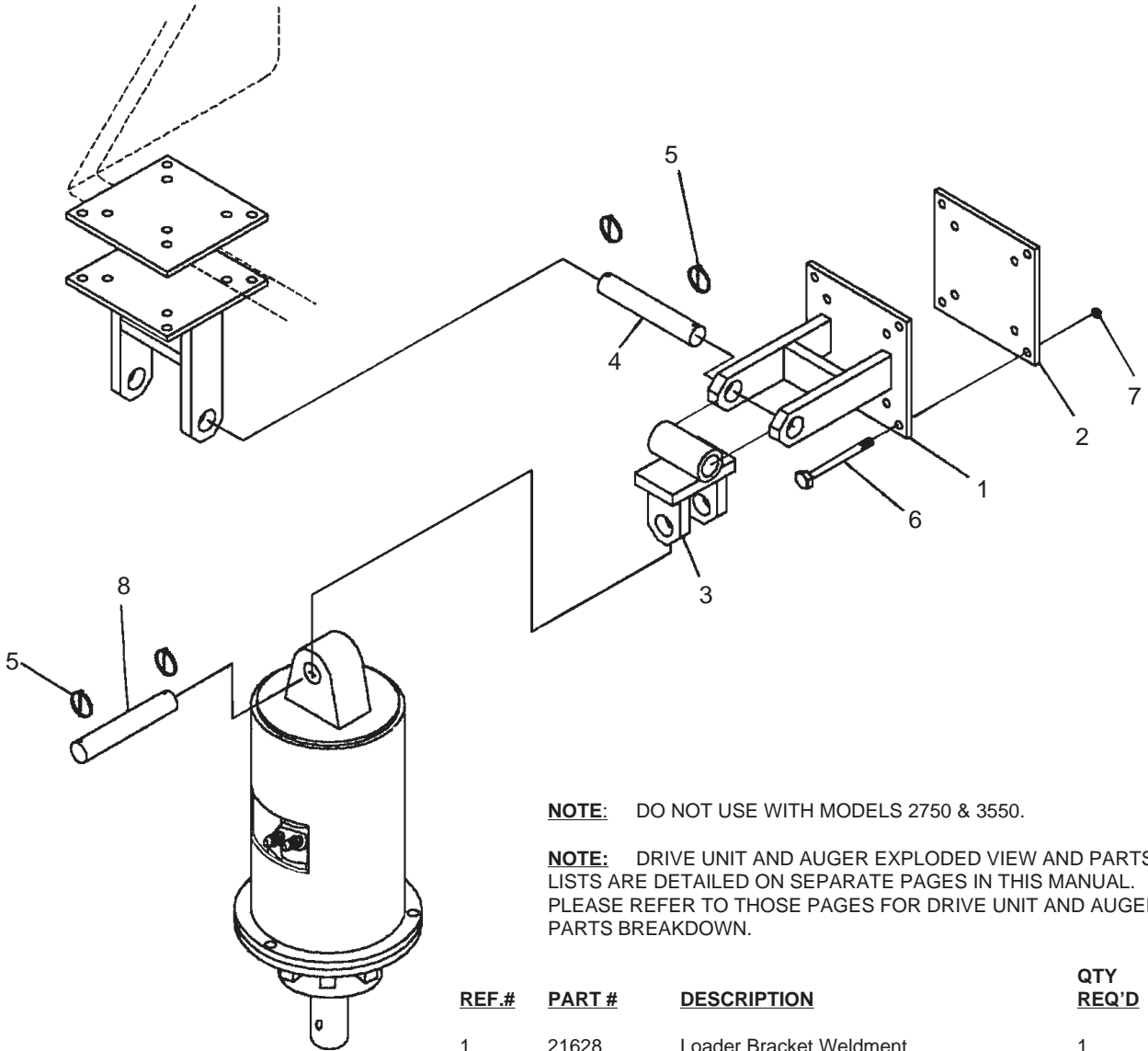

NOTE: DO NOT USE WITH MODELS 2750 & 3550.

NOTE: DRIVE UNIT AND AUGER EXPLODED VIEW AND PARTS LISTS ARE DETAILED ON SEPARATE PAGES IN THIS MANUAL. PLEASE REFER TO THOSE PAGES FOR DRIVE UNIT AND AUGER PARTS BREAKDOWN.

REF.#	PART #	DESCRIPTION	QTY REQ'D
1	21628	Loader Bracket Weldment	1
2	21449	Loader Bracket Pad (Included with Item #1)	1
3	21694	Swivel Weldment	1
4	22255	Pin, 1.25" 0 x 7.25" Long	1
5	21169	Lynch Pins	4
6	1080	.44"-14 x 5.00" Gr. 5 Bolt	4
7	1227	.44"-14 Hex Nut	4
8	22256	Pin (included with drive unit)	1

1. READ AND UNDERSTAND ALL SAFETY INFORMATION PRIOR TO ATTEMPTING INSTALLATION.
2. The #21235 Universal Loader Mounting can be used to adapt your McMillen Hydraulic Earth Drill to the side of the loader arms, lip of bucket or fork lift forks. DO NOT USE ON SKID STEER LOADERS.
3. Place loader bracket pad (2) on the inside of the loader arm, top of bucket lip (for mounting on lip of bucket you'll need to drill two 7/16" diameter holes through bucket), or top of fork lift fork. Opposite side of loader bracket pad (2). Insert four bolts (6) and secure with four nuts (7).
4. Attach swivel Weldment (3) to the loader bracket weldment (1) with pin (4). Secure pin (4) with Lynch Pins (5).
5. Attach and secure drive unit to swivel weldment (3) with pin and pin clips provided with the drive unit assembly.
6. Attach and secure auger to drive unit with bolt and nut provided with drive unit assembly.
7. Refer to the 'HYDRAULIC SYSTEM HOOK-UP' section in this manual for hydraulic connection instructions and recommendations.

#21272 3-POINT HITCH MOUNTINGS EXPLODED VIEW

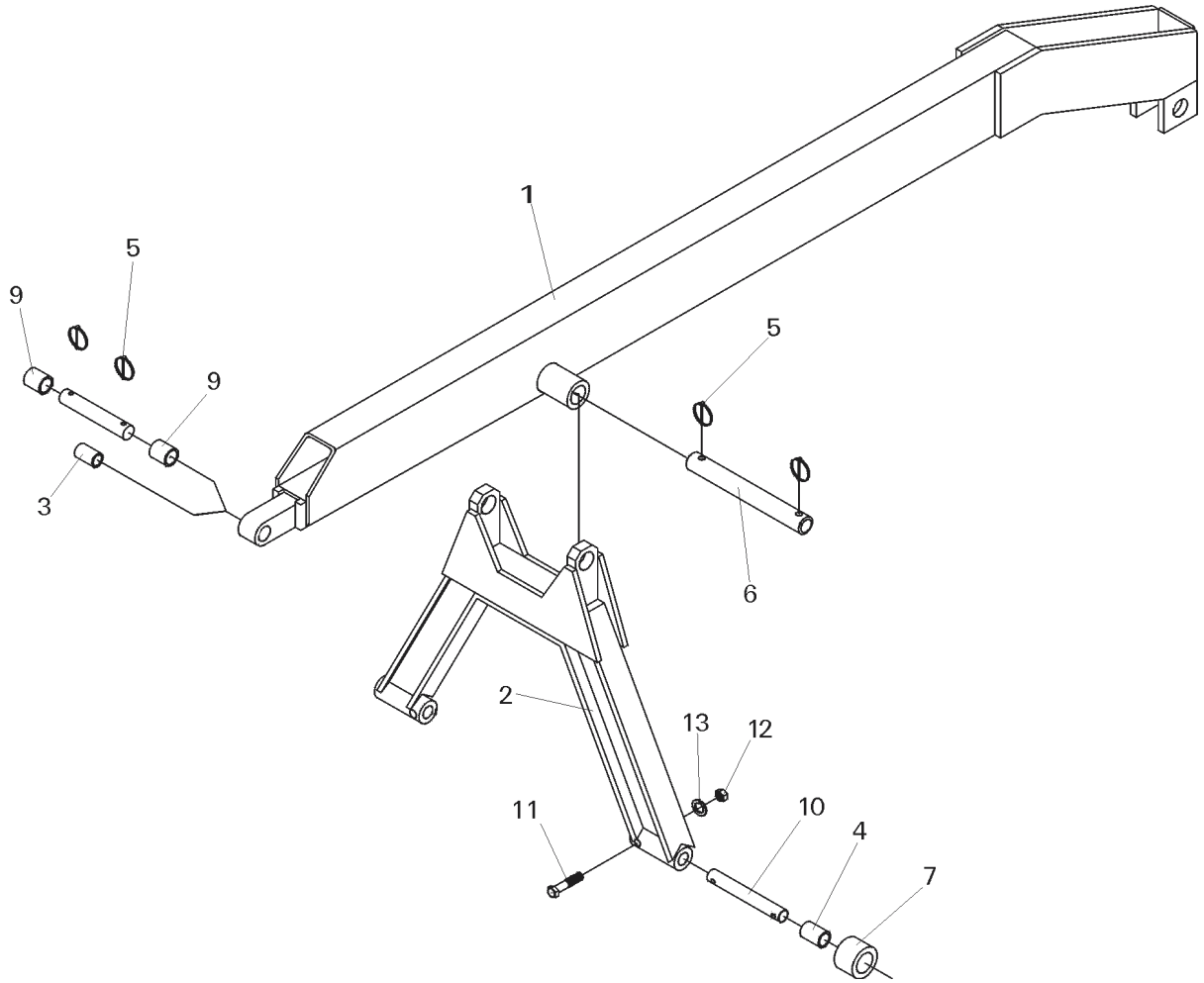

<u>REF. #</u>	<u>PART #</u>	<u>DESCRIPTION</u>	<u>QTY REQ'D</u>
1	21649	Boom	1
2	21638	A-frame	1
3	22225	Bushing, 1.00" OD x .75" ID x 1.56" Long	1
4	22226	Bushing, 1.12" OD x .88" ID x 1.62" Long	2
5	21169	Lynch Pins	4
6	22258	Pin, 1.25" x 10.31" Long	1
7	22227	Bushing, 1.44" OD x 1.12" ID x 1.62" Long	2
8	22254	Pin, 1.00" x 5.75" Long	1
9	22228	Bushing, 1.25" OD x 1.00"	2
10	22259	Pin, 1.00" x 6.44" Long	2
11	1070	.44"-14 x 2.00" Hex Head Capscrew	2
12	1227	.44"-14 Hex Nut	2
13	1515	.44" Flat Washer	2
-	22656	Decal	2

#21272 3-POINT HITCH MOUNTINGS

PARTS LIST AND INSTALLATION INSTRUCTIONS

1. **READ AND UNDERSTAND ALL SAFETY INFORMATION PRIOR TO ATTEMPTING INSTALLATION.**
2. Connect A-frame(2) to lift arm pins of your tractor three-point hitch by sliding A-frame lift arm pins into lift arms on Category II hitch, use bushings (4) on A-frame lift arm pins. Secure A-frame lift arm pins to lift arms with lynch pins (not provided).
 - A. For #21272 if the tractor has a Category III hitch, an additional set of bushings (7) are supplied to slip over the Category II bushings (4).
3. Connect the tractor end of the boom (1) to the top link bracket on your tractor using your tractor upper link pin and secure. If you are attaching to a Category II tractor, bushing (3) is not required but should be saved for future use.
 - A. For #21272 if you are attaching to a Category III tractor, replace the tractor top link pin with the top link pin (8) supplied. Use the two bushings (9) in the holes on each side of the top link bracket. Secure pin (8) with two lynch pins(5).
4. Swing A-frame (2) up and attach and secure to boom (1) with pin (6) and lynch pins (5).
5. Before proceeding further, slowly raise and lower the boom through its complete operating arch and check closely that there are no interferences. If there is any interference, make the proper three point hitch adjustments as per tractor manufacturers recommendations. **CAUTION!** - Consult your tractor dealer before making any modifications as any changes may present a serious safety hazard.
6. Attach and secure auger to drive unit with bolt and nut provided with drive unit assembly.
7. Attach and secure auger to drive unit with bolt and nut provided with drive unit assembly. If additional boom height is required to provide ground clearance for auger, make the proper three point hitch adjustments as per tractor manufacturers recommendations. **CAUTION!** - Consult the tractor dealer before making any modifications as changes may present a serious safety hazard.
8. Refer to the “HYDRAULIC SYSTEM HOOK-UP” section in this manual for hydraulic connection instructions and recommendations.

#21273 DOWN PRESSURE KIT EXPLODED VIEW & PARTS LIST

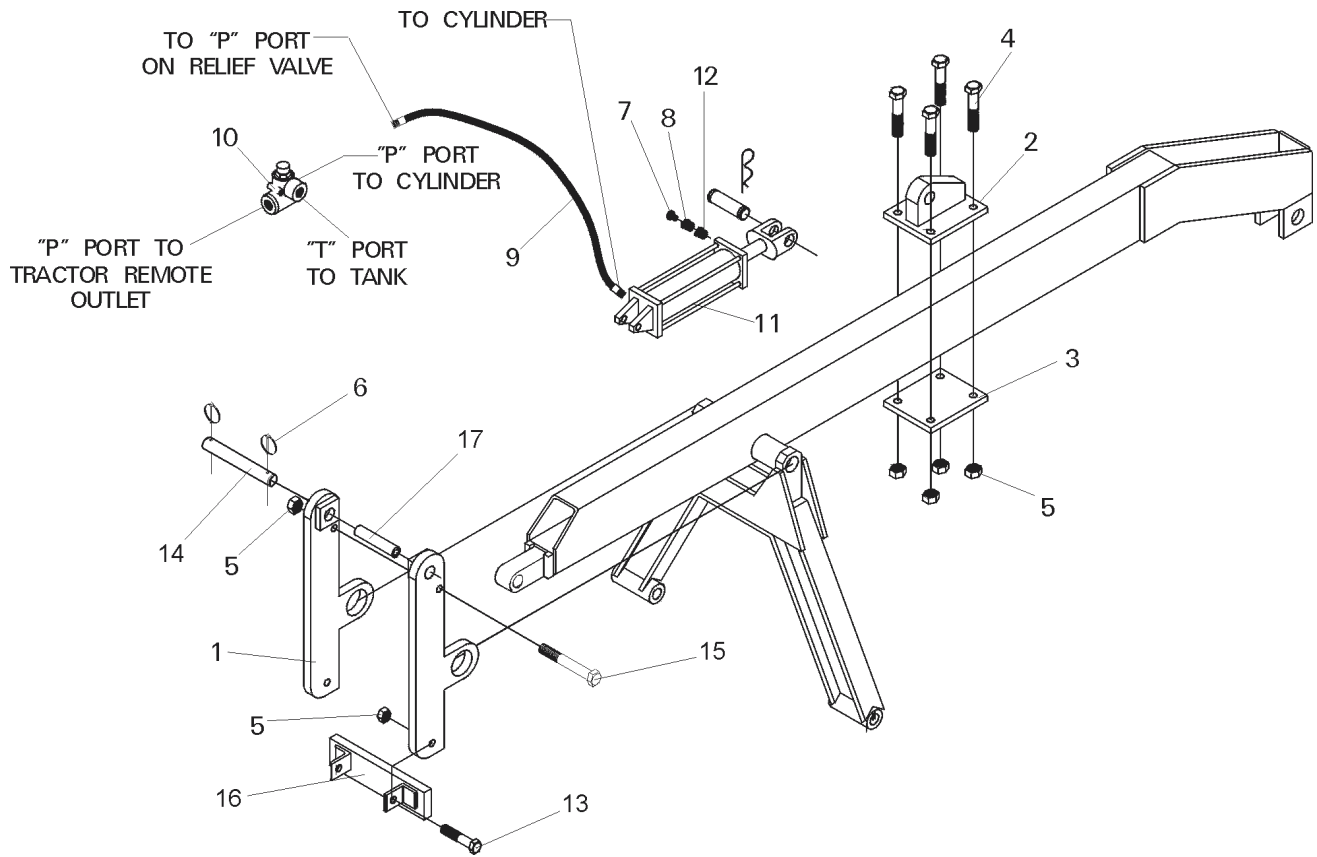

<u>REF. #</u>	<u>PART #</u>	<u>DESCRIPTION</u>	<u>QTY REQ'D</u>
1	23500	Pivot Push Arm Weldments, Right	
	23501	Pivot Push Arm Weldments, Left	
2	21655	Push Block Weldment	1
3	21435	Push Block Pad	1
4	1105	Bolt .50"-13 x 6.50" HHCS Gr. 5	4
5	1841	.50" Uni-Torque Lock Nut	7
6	21169	Lynch Pins	2
7	22588	.50" Flush Head Bronze Breather Vent	1
8	22607	.38" Female to 1/4" Male NPT Reducer	1
9	22606	.50" ID Double Wire Braid 3500 PSI Rated Hydraulic Hose 36" Long, .50" Male NPT Both ends.	1
10	22605	Relief Valve	1
11	22604	2" Bore Cyl 8" Stroke with .50" NPT Ports	1
12	22608	.50" NPT Male to .38" NPT Female Reducer	1
13	1091	Bolt, .50"-13 x 1.75" HHCS Gr. 5	2
14	21653	Pin 1" x 7" Long	1
15	1104	Bolt .50"-13 x 6" HHCS Gr. 5	1
16	21656	Push Bar Weldment	1
17	21327	Spacer Tube	1
-	22681	X-Series Operator's Manual	1
-	22679	McMillen Decal	2

#21273 DOWN PRESSURE KIT INSTALLATION INSTRUCTIONS

1. DOWN PRESSURE KIT ASSEMBLY IS DESIGNED FOR ADAPTION TO MCMILLEN #21272 3-POINT HITCH MOUNTING ONLY. DO NOT ATTEMPT TO ADAPT TO ANY OTHER MCMILLEN 3-POINT MOUNTING.
2. TRACTOR MUST BE EQUIPPED WITH 3-WAY OR 4-WAY REMOTE CONTROL VALVE AND OUTLETS.
3. **CAUTION:** TO AVOID POSSIBLE INJURY, REMOVE AUGER AND DRIVE UNIT FROM BOOM BEFORE EACH INSTALLATION OF DOWN PRESSURE KIT.
4. Remove existing A-frame to boom pin. Install pivot push arm weldment (1) to boom. Reconnect boom to A-frame then to upper hitch point on tractor.
5. Raise boom to maximum lift height.
6. Attach rear of cylinder (11), with hose port up. To pivot push arm weldment (1) with pin (15) provided. Secure pin (15) with two lynch pins (6) provided. Retract cylinder (11) to its minimum length. Push pivot push arm weldment (1) so that the face is resting firmly against side of a-frame.
7. Loosely assemble push block weldment (2) and push block pad (3) to boom using four bolts (4), nuts (5), provided. Do not tighten bolts yet.
8. Attach rod end of cylinder (11) to push block weldment (2) using pin (12). Secure with pin clip (13) provided. Tighten four bolts (4) on push block weldment (2) and push block pad (3) evenly, making sure bracket is straight and square.
9. Attach hose assembly (9) to cylinder part facing us, at, rear of cylinder. **(NOTE: ONE LAYER OF JOINT TAPE SHOULD BE USED ON ALL TAPER PIPE THREAD FITTINGS. DO NOT LET TAPE EXTEND INSIDE OF FITTING AND DO NOT OVER TIGHTEN FITTING).**
10. Attach other end of hose (9) to one of the "P" port on relief valve (10). See note in step 9 regarding joint connections.
11. Attach a suitable quick coupler tip on the other "P" port on relief valve (10). The coupler tip is not included and must be obtained locally. Connect quick coupler tip and relief valve (10) to a remote hydraulic outlet on rear of tractor. If tractor is equipped with a 4-way remote control valve, there will be two outlets. Either one can be used depending upon which direction the operator prefers to move the control valve lever to apply down pressure.
12. The hose fittings to connect the relief valve (port marked "tank") to the tractor reservoir should be obtained locally. Hose and fittings must have a minimum pressure rating of 2500 PSI and should be 1/2" ID hose. The connection to reservoir can be made at an oil fill, oil level check, breather, or drain opening. It is preferable to connect at a point below the oil level to prevent oil foaming. The "tank" port on relief valve is 1/2" NPT-F.

#21273 DOWN PRESSURE KIT OPERATING INSTRUCTIONS

1. **CAUTION! BEFORE OPERATING DOWN PRESSURE KIT, MAKE SURE ALL HOSES ARE CLEAR OF ALL BOOM, A-FRAME AND PIVOT PUSH ARM MOVEMENT.**
2. To apply down pressure, move the remote outlet control valve lever in the proper direction. As long as lever is activated down pressure will be applied. Use only enough down pressure to assure positive penetration of auger into the ground. Excessive down pressure will cause the auger to stall.
3. To raise the boom, return control valve lever for down pressure to the neutral position. Activate lift arm control valve lever to raise boom. **CAUTION! NEVER ATTEMPT TO RAISE BOOM WITH DOWN PRESSURE CONTROL VALVE ACTIVATED. SERIOUS PERSONAL INJURY OR EQUIPMENT DAMAGE MAY RESULT.**

HYDRAULIC SYSTEM HOOK-UP INSTRUCTIONS

1. Once the installation instructions are complete, you are now ready to make the hydraulic connections necessary to operate your earth drill. **READ AND UNDERSTAND SAFETY INFORMATION PRIOR TO MAKING HYDRAULIC CONNECTIONS.**
2. Your equipment dealer is in the best position to advise you as to where the best place on your machine is to make the hydraulic connections to power your earth drill drive unit. The list below shows the most common places to “tap” into the hydraulic system on various types of machines.

SKID STEER LOADERS - Auxiliary hydraulic outlets.

WHEEL LOADERS & TRACTOR LOADERS - Auxiliary hydraulic outlets or bucket tilt (dump) cylinder circuit.

TRACTOR 3-POINT HITCHES - Remote (auxiliary hydraulic outlets).

FORKLIFTS - Auxiliary hydraulic outlets or side shift circuit.

3. Determine length of hydraulic hoses required to plumb drive unit into the place on your machine where you'll be “tapping” into the hydraulics. Be sure the two hydraulic hoses are long enough to perform at the full range of the earth drills' operating capacity.

Model 450 requires two 1/2”(12.7mm) or 3/4” (19mm) ID hydraulic hoses with 1/2” male N.P.T. fittings on one end of each hose to connect hoses to drive unit fittings.



WARNING! HOSES AND FITTINGS MUST HAVE A CONTINUOUS OPERATING PRESSURE RATING OF AT LEAST 25% HIGHER THAN HIGHEST PRESSURES OF THE SYSTEM YOU ARE “TAPPING” INTO.

4. Once all hydraulic connections have been made and checked for leaks and proper hose lengths, you are now ready to operate your earth drill. **READ AND UNDERSTAND OPERATING INSTRUCTIONS AND SAFETY INFORMATION PRIOR TO OPERATING YOUR EARTH DRILL.**

OPERATING INSTRUCTIONS

1. After all installation instructions have been completed, safety information read and understood and the rest of this operator's manual has been reviewed, your McMillen Hydraulic Earth Drill is now ready for use.
2. With the auger raised off the ground and the vehicle engine set at a low RPM, activate the earth drill control valve to determine position control valve lever must be in to turn auger in a forward (clockwise) rotation. This is the “digging” position.
3. Before beginning to dig, experiment with auger speed to determine a suitable auger RPM. Generally in light and sandy soil a high RPM is desirable. In hard, rocky, or frozen soils a slower RPM is desirable. To increase auger RPM, increase vehicle engine RPM. To decrease auger RPM, decrease vehicle engine RPM.
4. Return earth drill control valve to neutral position to stop the auger. Lower the auger to the ground so that only the center point penetrates the ground about 2” (51mm).
5. Activate the earth drill control valve so auger is turning in a forward (clockwise) rotation. Use only enough down pressure to assure positive penetration of auger into the ground. Ease up on down pressure if auger rotation slows down drastically or stalls. Excessive down pressure will cause the auger to stall frequently.
6. When auger has penetrated the ground about 24” (610mm), raise the auger from the hole to clean the dirt out. Repeat this procedure until the desired hole depth is obtained.
7. Once the required hole depth is reached, allow the auger to turn a few seconds at this depth to clean the hole.
8. Return the earth drill control valve to the neutral position to stop the rotation of the auger. Raise the auger out of the hole, move away from the hole, then activate the earth drill control valve to spin the loose soil off of the augers.

NOTE: Do not reverse the auger rotation to remove from the hole as loose soil on the auger flights will fall back into the hole.

OPERATING INSTRUCTIONS

9. If necessary, repeat steps 7 & 8 to obtain a cleaner hole.
10. In some soil conditions or when excessive down pressure is applied, auger may “screw” itself into the ground and become stuck causing earth drill to stall. If this happens, reverse the auger rotation (counter-clockwise) by moving the control valve lever to the reverse position and slowly raise the auger. Once unstuck, return the control valve lever to the forward rotation position and continue digging.
11. If the auger becomes lodged under rocks, roots, or other large obstructions, do not attempt to raise the auger out of the ground. See step 10 for proper procedure to relieve the auger.
12. Avoid excessive side loading to earth drill which can cause drive unit or auger damage.
13. Keep auger teeth and points in good condition. Check frequently and always keep spares on hand so they can be replaced as wear is detected to avoid damage to tooth holders and auger flighting.

MAINTENANCE INSTRUCTIONS

1. **CLEAN HYDRAULIC OIL IS ESSENTIAL!** 80% of all hydraulic component failures are caused by contamination of the hydraulic oil. Always keep all dirt and other contaminants from entering hydraulic system during disconnect and connect operations. Always use dust caps and plugs on all quick disconnects when not in use. Tightly cap all hydraulic openings to hold oil in and keep dirt and other contaminants from entering hydraulic systems.
2. **CHECK HYDRAULIC OIL DAILY FOR CONTAMINATION.** If contamination is present, determine the source of the problem.
3. **INSPECT ALL HYDRAULIC HOSE ASSEMBLIES DAILY** for cracked and brittle covers caused by excessive heat. Reduced viscosity of hydraulic oil occurs at higher operating temperatures and causes a breakdown of fluid additives such as wear inhibitors. Excessive heat will cause higher internal leakage in drive unit motor which will make the drive unit less efficient. It can also cause seals in the drive unit motor to become brittle and crack. Replacement of hoses before failure will prevent loss of hydraulic oil, time consuming “bleeding” of the system, hydraulic oil contamination, and component damage caused by cavitation. It will also reduce the chance of personal injury caused by hydraulic fluid.
4. **CHECK AUGER DAILY** for loose, worn or broken cutting teeth and point. Worn teeth or point can drastically affect auger penetration and greatly reduce auger life expectancy. Always keep spare teeth and points on hand. Some digging conditions may require checking teeth and point at more frequent intervals.
5. **CHECK DRIVE UNIT AND ALL ACCESSORIES DAILY** for loose, bent, cracked, or worn bolts and fasteners. Always use grade 5 or harder replacements bolts. Always use lockwashers with standard hex nuts or self locking nuts.
6. **CHECK ALL CONNECTING PINS DAILY** for bends, cracks, breaks, or wear. Replace if any of these conditions exist.
7. **CHECK DRIVE UNIT OUTPUT SHAFT DAILY** for bends, cracks, breaks, or wear. Replace if any of these conditions exist.
8. **WHEN STORING DRIVE UNIT** for any length of time be sure drive unit motor and hoses are full of clean oil.
9. Drive Unit output shaft, inside of auger collar, variable auger extension shaft, inside of variable auger extension collar and all connecting pins should be coated liberally with grease to prevent rust and reduce wear.
10. Once paint has been worn off auger, coat liberally with grease as required, to prevent rusting.
11. Check planetary gear oil as follows. Lie drive unit horizontal with ground place bottom drain plug straight up. Remove plug, tilt drive unit at 2:00 or 10:00. Fill until oil leaks out from hole at one of these positions.

MODEL X450 HYDRAULIC DRIVE UNIT

SPECIFICATIONS, EXPLODED VIEW, AND PARTS LIST

DRIVE UNIT MODEL X450 SPECIFICATIONS

Maximum Auger Diameter: 12" (305mm)
 Minimum Hydraulic Flow: 5 GPM (19 lpm)
 Maximum Hydraulic Flow: 10 GPM (38 lpm)
 Maximum Continuous Operating PSI: 3000 PSI (211 KG/cm²)

OUTPUT SPEED		OUTPUT TORQUE	
FLOW	SPEED	PRESSURE	TORQUE
GPM (LPM)	RPM	PSI(KG/CM ²)	FT/LBS(Nm)
5 (19)	= 65	2000 (141)	= 470 (637)
6 (23)	= 78	2100 (147)	= 493 (169)
7 (26)	= 91	2200 (155)	= 516 (700)
8 (30)	= 104	2300 (162)	= 540 (732)
9 (34)	= 117	2400 (169)	= 563 (763)
10 (38)	= 130	2500 (183)	= 587 (796)
		2600 (183)	= 610 (827)
		2700 (190)	= 634 (860)
		2800 (197)	= 657 (891)

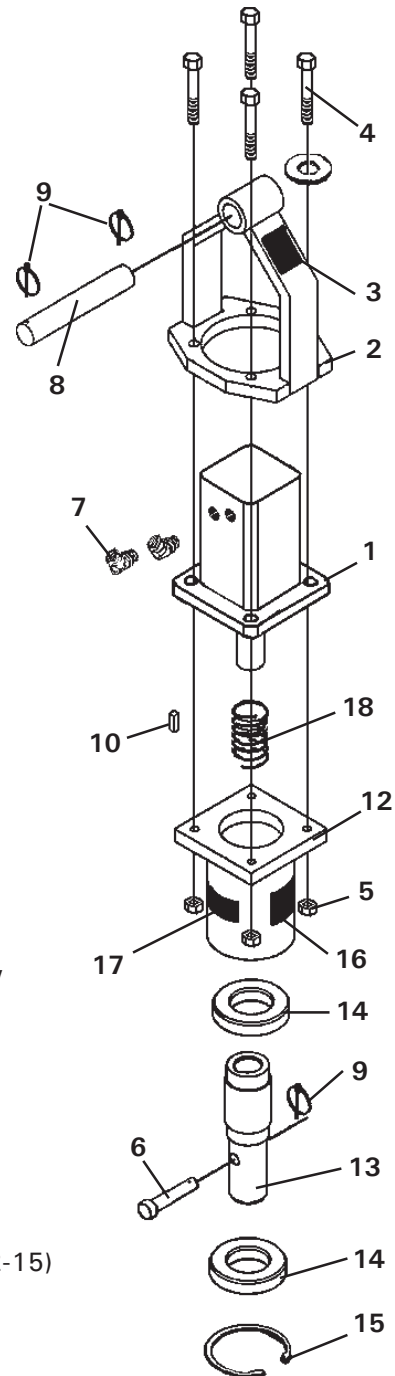

REF. #	QTY REQ'D	PART #	DESCRIPTION
1	1	21949	Hydraulic Motor 450
2	1	21662	Motor Mount Weldment
3	1	22677	Model #/Serial # ID Plate
4	4	22349	Drive Screws for I.D. Tag
4	4	1100	.50"-13 X 4.00" Hex Head Capscrew
5	4	1841	.50-13 "Uni-Torque" Lock Nut
6	1	22261	Clevis Pin
7	2	22593	45° "O" Ring Motor Fitting
8	1	22256	Pin, 1.25" x 6.00" Long
9	3	21169	Lynch Pins
10	1	5661	Key
11	--	21687	Adapter Assembly (Includes Items 12-15)
12	1	22229	Powerhead Housing
13	1	--	Powerhead Shaft
14	2	22246	Powerhead Bearing
15	1	1601	Powerhead Snap Ring
16	2	22680	Safety Decal
17	4	22679	McMillen Decal
18	1	22292	Spring
19	8	1527	.50 Flat Washer

TROUBLESHOOTING

PROBLEM	POSSIBLE CAUSE	SOLUTION
Slow Speed	Low Flow	Check with flow meter. If low investigate cause.
	Line restrictions	Clear lines.
	Fittings or connections too small	Replace with proper sizes.
	Oil filter dirty	Replace.
	Hydraulic pump worn or damaged	See Dealer for repair.
Insufficient Digging Power	Worn teeth or point	Replace
	Low system Pressure (PSI)	Check with pressure gauge. If low, investigate cause.
	Relief Valve damaged or setting wrong	Adjust or replace as required.
	Excessive load	Reduce load to within machine specifications.
Reverse Direction	Hoses reversed	Re-install hoses correctly.
Excessive Oil Heating	Line restrictions	Clear lines.
	Fluid dirty	Replace hydraulic fluid and filter.
	Insufficient quantity of hydraulic fluid	Fill reservoir to proper level. Increase reservoir storage capacity.
Oil Leaks	Hoses loose or damaged	Tighten or replace.
	Fittings loose or damaged	Tighten or replace.
	Hydraulic motor seals worn or damaged	See Dealer for repair.

FOR FURTHER ASSISTANCE PLEASE CALL YOUR DEALER, OR CONTACT OUR SERVICE DEPARTMENT AS FOLLOWS:

NORTH AMERICA TOLL FREE: (800) 234-0964
 Outside North America: (563) 922-2981
 Fax: (563) 922-2130

HDC STYLE AUGER WEAR PARTS LIST

AUGER DIA.	6"	8"	9"	10"	12"	15"	16"	18"	20"	24"	30"	36"	42"	48"
	152mm	203mm	229mm	254mm	305mm	381mm	406mm	457mm	508mm	610mm	762mm	914mm	1067mm	1219mm
Part #	Description(Standard Components)													
	Qty	Qty	Qty	Qty	Qty	Qty	Qty	Qty	Qty	Qty	Qty	Qty	Qty	Qty
22169	Hardened Drive-In Gage Tooth													
22168	Hardened Drive-In Wisdom Tooth													
22190	3.50" Hardened Fishtail Point (male shaft)													
22154	Rubber Lock													

HDF STYLE AUGER WEAR PARTS LIST

AUGER DIA.	4"	6"	8"	9"	10"	12"	15"	16"	18"	20"	24"	30"	36"
	102mm	152mm	203mm	229mm	254mm	305mm	381mm	406mm	457mm	508mm	610mm	762mm	914mm
Part #	Description(Standard Components)												
	Qty	Qty	Qty	Qty	Qty	Qty	Qty	Qty	Qty	Qty	Qty	Qty	Qty
22169	Hardened Bolt-on Gage Tooth												
22168	Hardened Bolt-on Wisdom Tooth												
22190	3.50" Hardened Fishtail Point (male shaft)												
22003	4.50" Hardened Fishtail Point												
22306	Carriage Bolt												
1839	Nut												

HTF STYLE AUGER WEAR PARTS LIST

AUGER DIA.	18"	24"	30"	36"	42"	48"
	457mm	610mm	762mm	914mm	1067mm	1219mm
Part #	Description(Standard Components)					
	QTY	QTY	QTY	QTY	QTY	QTY
22169	Hardened Bolt-on Gage Tooth					
22168	Hardened Bolt-on Wisdom Tooth					
22190	3.50" Hardened Fishtail Point (male shaft)					
22306	Carriage Bolt					
1839	Nut					

OPTIONAL HARDFACED & CARBIDE WEAR COMPONENTS

Part #	Description
22170	Hardfaced Wisdom Tooth
22186	Carbide Wisdom Tooth
22181	Hardened Chisel Tooth
22183	Hardfaced Chisel Tooth
22182	Carbide Chisel Tooth
22190	3.50" Hardened Fishtail Point (Male Hub)
22192	3.50" Hardfaced Fishtail Point (Male Hub)
22191	3.50" Carbide Fishtail Point (Male Hub)
22193	3.50" Hardfaced /Carbide Fishtail Point (Male Hub)
22003	4.50" Hardened Fishtail Point (Female)
22004	4.50" Hardfaced Fishtail Point (Female)
22005	4.50" Hardfaced /Carbide Fishtail Point (Female)
22171	3.50" Hardened Fishtail Point (Female)
22172	3.50" Carbide Fishtail Point (Female)
22173	3.50" Hardfaced Fishtail Point (Female)
22174	3.50" Hardfaced /Carbide Fishtail Point (Female)

IMPORTANT: McMillen does not recommend augers exceeding 36" diameter for C-Series Drive Units.

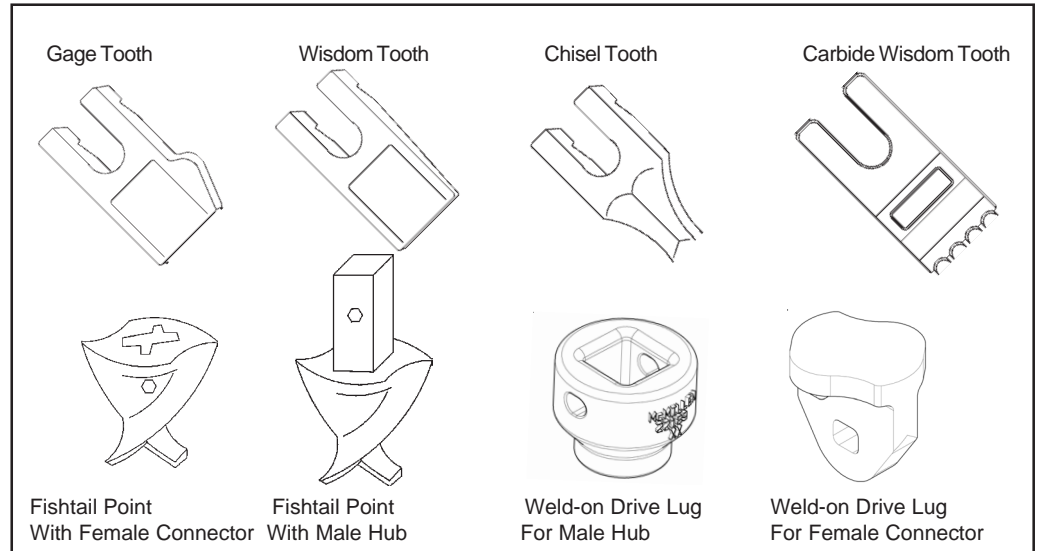

NOTE: Contact your equipment dealer for wear components not listed above. If you have any special auger needs or applications, feel free to contact McMillen.

